



MASTERCART SERIES 95 US gal / 360 L



Colors (Standard)



Available options for lid



• Strong, resistant lid



• Standardized lip for European or American grip



• Advanced lid hinge design



• Option of heavy duty quiet solid wheels



70 YEARS OF EXPERTISE
in design and manufacture

MUCH MORE THAN A SIMPLE PRODUCT we offer custom-tailored service

SUPERIOR QUALITY COMPONENTS designed for the North American climate

www.ipl-plastics.com
1 800 463-0270

Our vision for a better future

IPL is committed to reducing the environmental impact of its activities, manufacturing processes, products and services.



MASTERCART SERIES 95 US gal / 360 L

KEY FEATURES

- Injection molded cart for strength and durability
- The IPL injection mold process produces exacting design and yields consistent thickness, precision and cost effectiveness.
- UV stabilized against long term effects of the sun.

WHEELS

- Solid steel axle, yellow-zinc plated against corrosion
- Wheels snap on without tools

BODY

- Carts are 100% recyclable
- Unibody design with no bolts or holes that could potentially leak
- Designed for maximum wind stability
- Easy to handle

LID

- Advanced lid hinge design offers a tight seal that keeps pests and weather out and trash in.
- Safe lid: can support the weight of a child
- Multilingual user instructions on the lid

TRACKING

- RFID tag and bar code enabled

DECORATION

- Multicolor hot stamping branded logos, serial numbers
- Sequential serial numbers, bar coding

WARRANTY

- 10-year limited warranty
- 20-year life expectancy that can take the worst weather and the roughest handling
- Longest lasting cart in North America
- Meets all American National Standards Institute requirements for safety and lifter system compatibility. (ANSI Z245.30 and Z245.60)

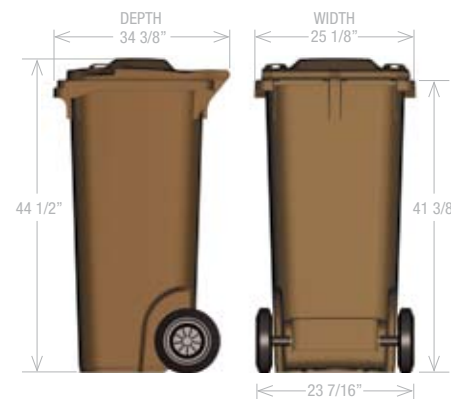

TECHNICAL SPECIFICATIONS

PRODUCT #		60269	
Specifications (American and European style)		95 US gal	360L
Cart & lid		Injection molded	
Sizes	Depth	34 3/8 in	88.3 cm
	Width	25 1/8 in	63.8 cm
	Height	44 1/2 in	113.03 cm
Wall thickness (avg.)		.160 in	0.39 cm
Rubber Wheel diameter			
Rubber Wheel # 6131009908		12 in	30.5 cm
Dual Wheel # 61890099		12 in	30.5 cm
Wheel/Axle 7/8 in. #6410228		22.7 in	57.7 cm
Weight w/Rubber wheel (approx.)		44.8 lbs	20.3 kg
Weight w/Dual wheel (approx.)		39 lbs	17.7 kg
Raw material		HDPE	
Recycling code		2	
Bottom wear strips		3/8 in	.95 cm
Catch bar		Metal bar only	
Thermal Resistance		-40 °F to 102 °F	-40 °C to 39 °C
Load rating		250 lbs	113.5 kg
Wind Tunnel	Front	48 mph	
	Side	45 mph	
	Back	60 mph	
Dimensions may vary +/- 2%			

SHIPPING INFORMATION

	Qty
T/L quantity (53') Assembled	513
T/L quantity (53') Not ass.	594
Collection system	Manual or semi/fully automated system (recommended)

IMPRINT

Side cart	9 in x 11 in	22.9 cm x 27.9 cm
Front cart American	4 in x 11 in	10.1 cm x 25.4 cm
Front cart European	9 in x 9 in or 8 in x 11 in	22.9 cm x 22.9 cm or 20.3 cm x 27.9 cm
Lid (between the handles)	N/A	22.9 cm x 27.9 cm
Top of the lid #63562	7 in x 7 in	17.8 cm x 17.8 cm
	5 in x 5 in	12.7 cm x 12.7 cm

COLORS (STANDARD)

Green 363	Blue 285	Charcoal 447	Brown 462	Black 099
-----------	----------	--------------	-----------	-----------

Other colors available upon request

www.ipl-plastics.com

1 800 463-0270

Our vision for a better future

IPL is committed to reducing the environmental impact of its activities, manufacturing processes, products and services.

